

DTN2070 differential pressure transmitter



Key features

- Advanced thin film metal strain gauge sensor technology
- Stainless steel housings, non-painted
- Seismically qualified stainless steel mounting brackets
- Loop powered, 2 wire, 4-20 mA
- Quarter inch NPT process connections
- Dustproof and waterproof construction, no humidity effect

Overview

Curtiss-Wright's DTN2070 differential pressure transmitters are designed to provide reliable and precise pressure measurements in nuclear applications operating in harsh environments. It meets the most stringent environmental requirements of Gen III+ reactors for harsh operating environments and post-accident monitoring applications inside containment. The DTN2070 contains only analog electronics, using a diaphragm isolated direct coupled strain gauge pressure sensor capsule. The DTN2070 has undergone complete seismic and environmental qualification, being Class 1E qualified to IEEE 323-1974 and IEEE 344- 1987.

Technical data

Feature	Description
Reference accuracy	±0.25% of span, typical < 0.15%, includes linearity, hysteresis, deadband, settability and repeatability
Stability/drift	±0.25% of URL per 30 months at reference conditions
Static pressure zero effect	±0.25% URL for 1,000 psi static pressure change. This effect is systematic and can be calibrated out for a particular pressure before installation
Zero overpressure effects (per 1000 psi/6.89 Mpa)	±0.25% URL one-sided, ±1% URL two-sided sequential
Field adjustability (zero and span) for harsh environment models	±15% of span, within the transmitter URL
Field adjustability (zero and span) for non-safety, mild and non-submergence models	Zero: ±70% of URL, Span: ±33% to ±100% of URL
Direct or reverse acting capabilities	Factory set and can't be changed in the field
Operating temperature	40°F to 257°F (4.4°C to 125°C) normal services. Operating temperatures will affect qualified life
Zero elevation, zero suppression factory set	Zero elevation and suppression must be such that neither the calibrated span nor the upper or lower range value exceeds 100% of the URL
Turn-on time	2 seconds or less, 1 minute for rated accuracy
Storage temperature	-40°F to 257°F (-40°C to 125°C). Storage temperature will affect qualified life.
Output signal	4-20 mA two wire only

Technical data

Feature	Description
Response time, range code 200	≤1.5 sec, sensor response time to 50% with a 100% span step change at 100°F (37.8°C)
Response time, range code 300	≤0.7 sec, sensor response time to 50% with a 100% span step change at 100°F (37.8°C)
Response time, range code 400 and 600	≤0.4 sec, sensor response time to 50% with a 100% span step change at 100°F (37.8°C)
Response time, range code 850	≤0.25 sec, sensor response time to 50% with a 100% span step change at 100°F (37.8°C)
Damping	Factory set, 0 or 1.6 seconds
Power supply effect	0.005% of calibration span/volt
Min current limit	3.4 +/- .1 mA
Max current limit	21.6 +/- .2 mA
Power supply load limitations	18 VDC to 48 VDC (mild); 18 VDC to 33 VDC (harsh); $R (\Omega) = \text{maximum field loop resistance} = 46.3 * (\text{power supply voltage} - 18)$
Load effect	Within limits set by the line voltage, the output current is independent of load resistance
Mounting position effect	No span effect; zero shift of up to 1.5 inH ₂ O (0.249 kPa) which can be calibrated out
EMC/EMI compliance	Satisfies requirements defined in: US NRC Reg. Guide 1.180 Rev. 1. European EMC Directive 2014/30/EU by conforming to applicable EN and IEC Standards: compliance testing to the EN 61000 Series standards, CE marking, declaration of conformity

Technical data

Feature	Description
Transient protection	Meets Criteria A of IEC 61000-4-4:1995 (electrical fast transient/burst immunity test; power and I/O line burst: 2kV, 15/300 ms, 5kHz)
PED and CE mark	Fully compliant
Temperature effects (per 50°F/ 27.8°C)	Above 130°F (54.4°C), determine the error from 130°F to the temperature of interest then add the 130°F error.
Harsh Environments 40°F to 130°F (4.4°C to 54.4°C)	Range Codes 200, 300, 400: ±0.6% URL + 0.4% span; range codes 600: ±0.35% URL +1.0% span; range code 850: ±0.6% URL + 1.2% span
Harsh Environments 130°F to 257°F* (54.4°C to 125°C)	Range codes 200-600: ±0.7% URL; range code 850: ±1.35% URL (see note above, temperature effects above 130°F)
Mild, rad harsh and submergence 40°F to 130°F (4.4°C to 54.4°C)	Range codes 200-850 ± 0.50% URL
Power supply requirements	18 VDC to 48 VDC (see also DTN2070 power supply load limits later in this document for load resistance requirements.)
Range down	3.5 to 1 (minimum span is 28.6% URL)
Volumetric displacement	< 0.005 in ³ (0.082 cm ³)
Enclosure rating	NEMA 6P (IP 68)
Humidity Limits	0-100% RH, submergence
Isolating diaphragms	Range 200, 300, 400 and 850: Hastelloy™ Alloy-C; Range 600: Stainless 17-7 PH
Drain vent valve	None

Technical data

Feature	Description
Process flange	316 SST
Process seal	EPDM
Electronics housing O-ring	EPDM
Fill fluid	Silicone oil - DC550
Sensor module and electronics housing	316 SST
Flange bolts	Medium carbon alloy steel, SAE J429, Grade 8, Zinc yellow-chromate plated finish per ASTM B633
Mounting bracket	304 SST
Mounting bolts	300 Series stainless steel, ASTM F593
Process connections	1/4-18 NPT Optional: 3/8" welded fittings
Electrical connections	Gen 3 Quick Disconnect Connector (QDC); seal gland with 8 feet leads
Weight	16.9 lbs. (7.66 kg) with mounting bracket, bolts and SST tag. 14.9 lbs. (6.82 kg) transmitter only. 1.9 lbs. (0.36 kg) mounting bracket
Traceability	Per 10CFR50 Appendix B, 10CFR21, NQA-1, and ISO 9001:2008; chemical and physical certification of pressure retaining parts.
Service Life	23.4 years at 100° F (37.8°C) (see 'Qualified service life vs. temperature' towards the end of this document for details.)

Technical data

Feature	Description
Fix-fasten	Specifications listed reflect maximum error during seismic disturbance. All ranges: accuracy within $\pm 0.5\%$ URL for OBE at 1/2 SSE, accuracy within $\pm 0.7\%$ URL for SSE Transmitters will return to within $\pm 0.20\%$ after the event. (see "Seismic - Test Response Spectra, 5% Damping" towards the end of this document tab for details.)
Seismic accuracy	Specifications listed reflect maximum error during seismic disturbance. All ranges: accuracy within $\pm 0.5\%$ URL for OBE at 1/2 SSE, accuracy within $\pm 0.7\%$ URL for SSE Transmitters will return to within $\pm 0.20\%$ after the event. (see 'Seismic - Test Response Spectra, 5% Damping' towards the end of this document tab for details.)
During LOCA	+ 4.0 % of URL for DPs first 15 days and submergence, excludes radiation (See 'Actual LOCA/PAMS chamber temperature' towards the end of this documents for details.)
During PAMS	+ 2.7% of URL 43 days (See 'Actual LOCA/PAMS chamber temperature' towards the end of this documents for details.)
Environmental/seismic qualifications	IEEE 323-1974 and 323-1983, IEEE 344-75 & IEEE 344-87

Technical specifications

Model updates

The transmitter has been updated over the years to improve performance and to deal with component obsolescence. The sensing capsule of the DTN2070 - Westinghouse Veritrac/ Tobar/ Camille Bauer Model 32, and most recently Weed Instrument DTN2010 and N97 - has the same field-proven, underlying design as the Model 32 originally qualified in 1982.

Service live vs. temperature

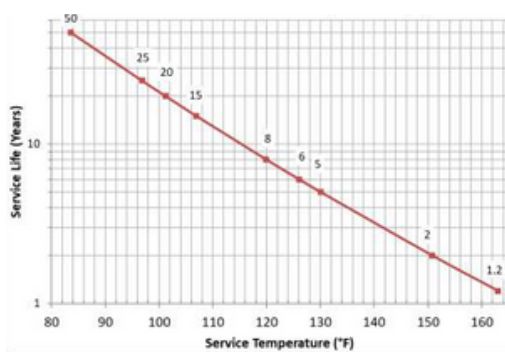
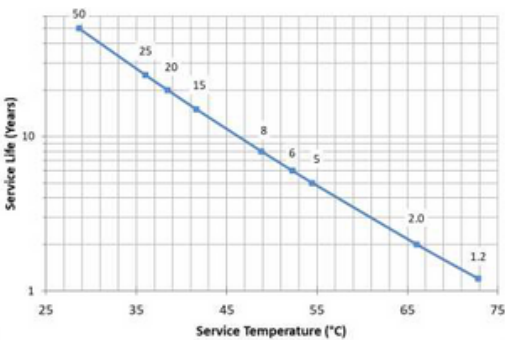

Ranges and limits

Imperial Units

	Range Code	Diaphragm Material	URL inH ₂ O @20°C	Span Range inH ₂ O	Static Pressure / Overpressure Limit
DP	200	Hastelloy - C	40	11 to 40	2,538 psi
	300	Hastelloy - C	100	29 to 100	
	400	Hastelloy - C	250	71 to 250	
	600	Stainless 17-7PH	650	31 to 650	
	850	Hastelloy - C	956	273 to 956	

Metric Units

	Range Code	Diaphragm Material	URL kPa	Span Range kPa	Static Pressure / Overpressure Limit
DP	200	Hastelloy - C	9.95	3 to 9.95	17.5 MPa
	300	Hastelloy - C	25	7 to 25	
	400	Hastelloy - C	62	18 to 62	
	600	Stainless 17-7PH	162	46 to 162	
	850	Hastelloy - C	238	68 to 238	

Power supply load limitations, 4-20 mA

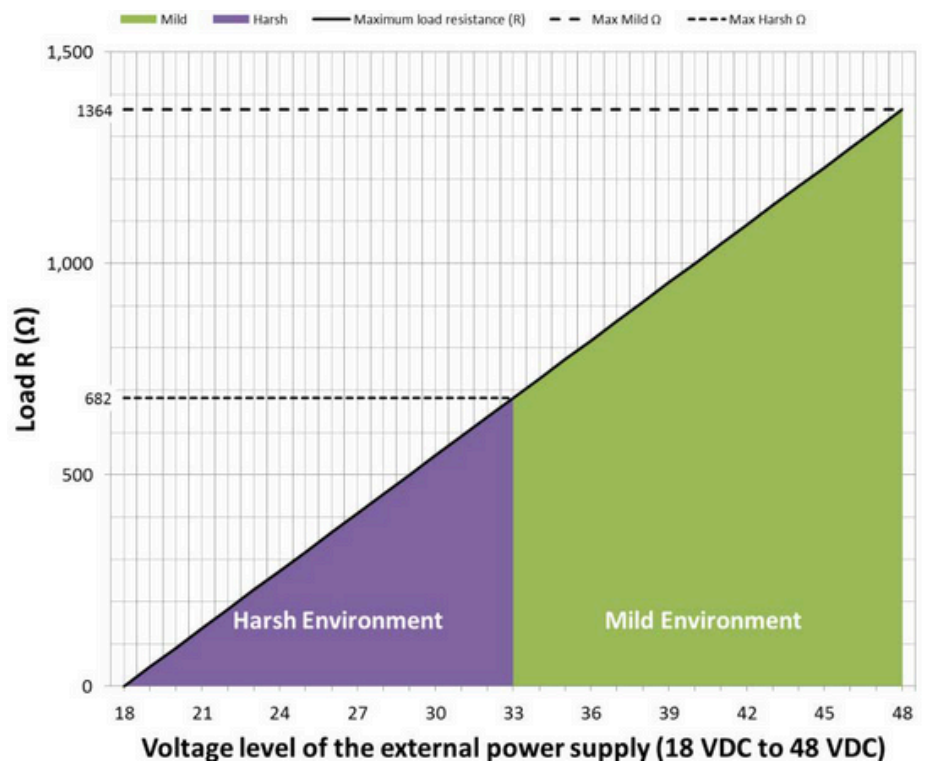

Technical specifications

Seismic test response spectra, 5% damping

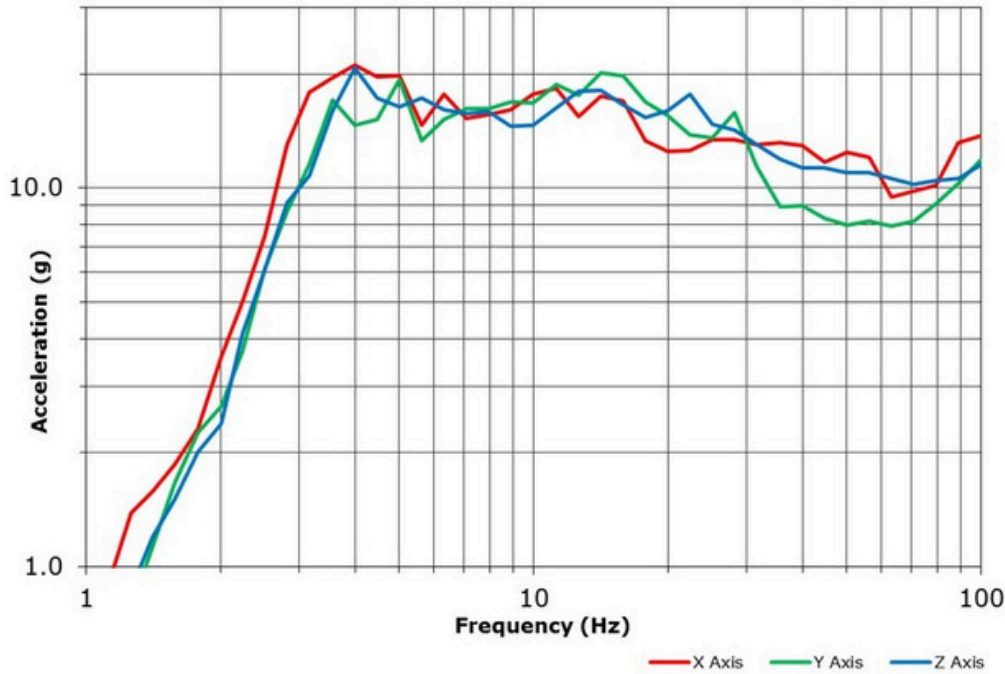

Seismic – Test Response Spectra, 5% Damping.

Actual LOCA/PAMS chamber temperature

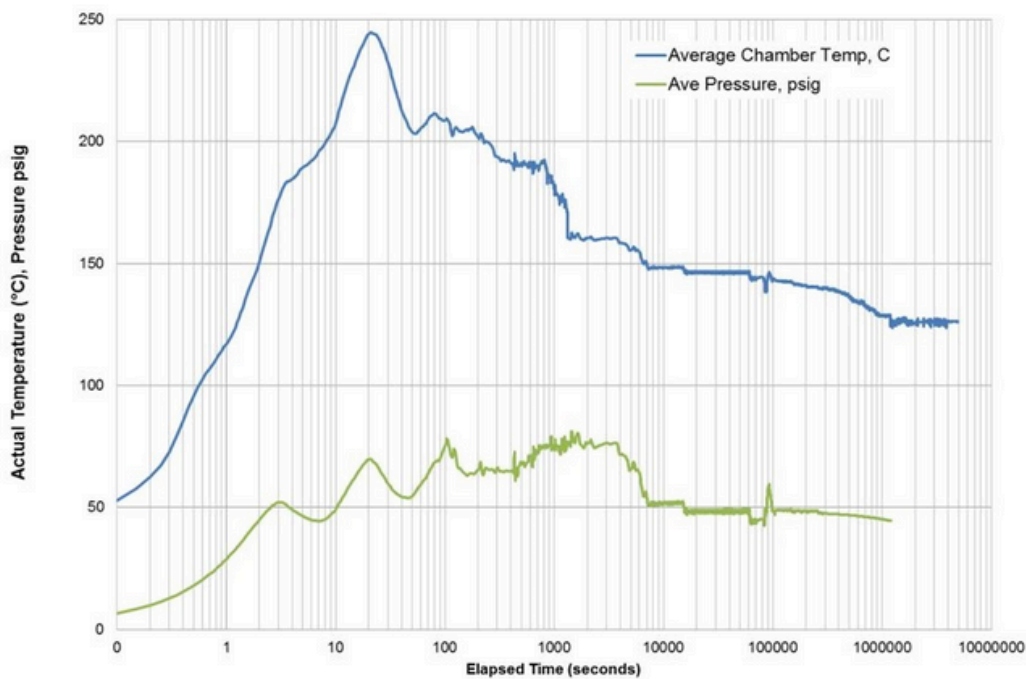

Technical specifications

Dimensional drawings

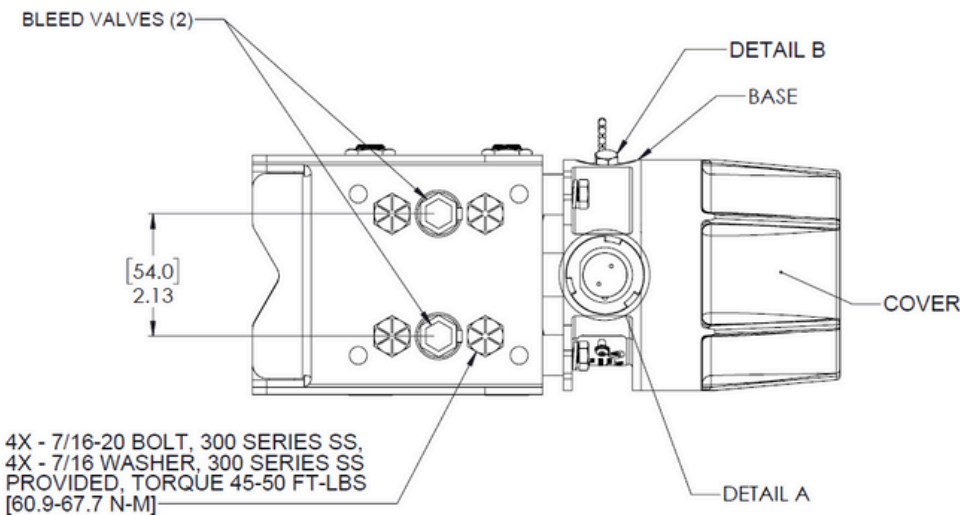
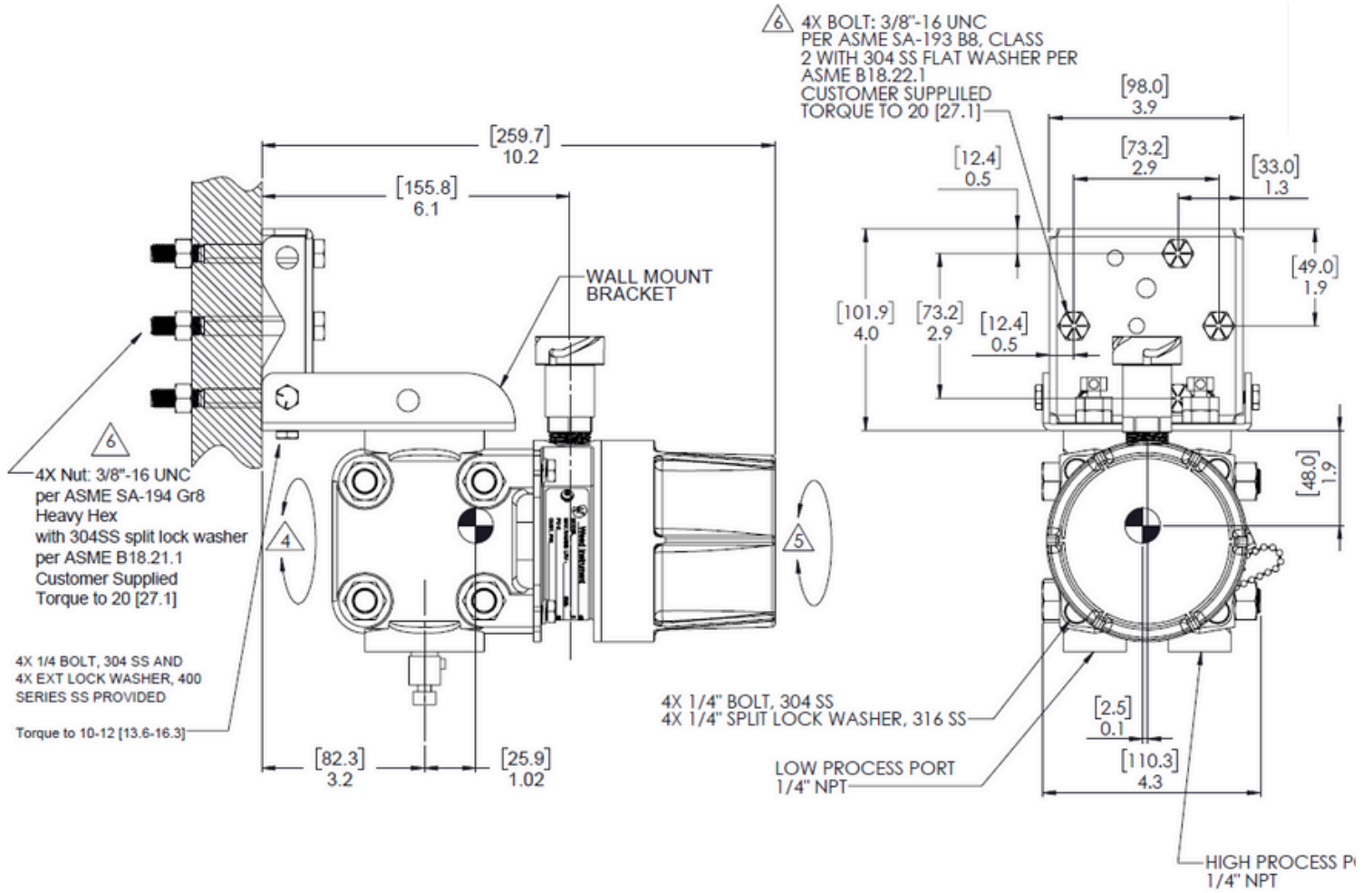

United States of America

707 Jeffrey Way
Round Rock
Texas 78665-2408
USA

Tel: +1 512-434-2800

United Kingdom

Innovation House
Lancaster Road
Ferndown Industrial Estate
Wimborne
Dorset BH21 7SQ
UK

Tel: +44 (0) 1202 850 450

For more information

Web: cwic.curtisswright.com

Email: sales@nspi.curtisswright.com

About Curtiss-Wright

Curtiss-Wright Round Rock and Wimborne have worked with nuclear and industrial customers for over 60 years. We support customers across the world from facilities located in the US and UK. Our solutions are embedded in strategic national infrastructure and our people are active partners in customer programs that are focused on delivering advanced future nuclear and industrial capabilities.

Curtiss-Wright Corporation (NYSE: CW) is a global integrated business that provides highly engineered products, solutions and services mainly to Aerospace & Defense markets, as well as critical technologies in demanding commercial power, process and industrial markets. We leverage a workforce of approximately 8,600 highly skilled employees who develop, design and build what we believe are the best engineered solutions to the markets we serve. Building on the heritage of Glenn Curtiss and the Wright brothers, Curtiss-Wright has a long tradition of providing innovative solutions through trusted customer relationships.