

General purpose aluminum ATEX approved connection head code 19



Overview

Standard style instrument connection head suitable for temperature sensor assemblies.

Connection head supplied with terminal block unless a temperature transmitter is ordered.

ATEX approved and meets NEMA 4 requirements.

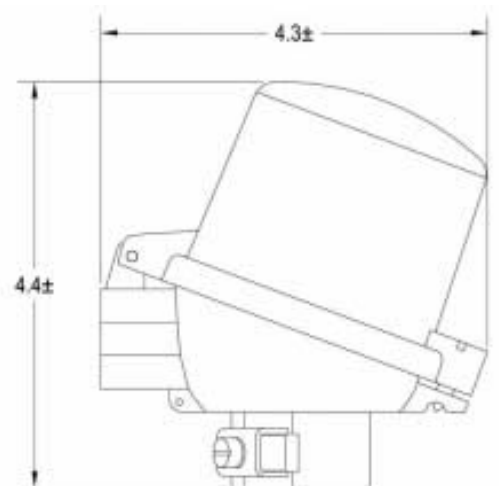

Technical specification

Feature	Description
Extension style	Standard none, with optional nipple, nipple/union, nipple/union/nipple, union/nipple
Extension length	Standard none, with optional 1 to 6 inches or custom lengths
Conduit connection	Standard 3/4" NPT, with optional 1/2" NPT
Terminal block (accessory)	Phenolic or ceramic

Code	Description																		
19	General Purpose Aluminum ATEX Approved																		
	<table border="1"> <thead> <tr> <th>Code</th> <th>General Extension Style and Material</th> </tr> </thead> <tbody> <tr> <td>A</td> <td>None. For sensors with threaded instrument connections (i.e. model 305); or when ordered as a stand alone.</td> </tr> <tr> <td>F</td> <td>Nipple extension - Series 300 stainless steel (F=00 for close nipple).</td> </tr> <tr> <td>G</td> <td>Nipple/union Series 300 stainless steel 3" minimum.</td> </tr> <tr> <td>H</td> <td>Nipple/union/nipple Series 300 stainless steel 3" minimum.</td> </tr> <tr> <td>J</td> <td>Union/nipple - Series 300 stainless steel 3" minimum.</td> </tr> </tbody> </table>	Code	General Extension Style and Material	A	None. For sensors with threaded instrument connections (i.e. model 305); or when ordered as a stand alone.	F	Nipple extension - Series 300 stainless steel (F=00 for close nipple).	G	Nipple/union Series 300 stainless steel 3" minimum.	H	Nipple/union/nipple Series 300 stainless steel 3" minimum.	J	Union/nipple - Series 300 stainless steel 3" minimum.						
Code	General Extension Style and Material																		
A	None. For sensors with threaded instrument connections (i.e. model 305); or when ordered as a stand alone.																		
F	Nipple extension - Series 300 stainless steel (F=00 for close nipple).																		
G	Nipple/union Series 300 stainless steel 3" minimum.																		
H	Nipple/union/nipple Series 300 stainless steel 3" minimum.																		
J	Union/nipple - Series 300 stainless steel 3" minimum.																		
	<table border="1"> <thead> <tr> <th>Code</th> <th>Extension Length ("B" Dimension)</th> </tr> </thead> <tbody> <tr> <td>00</td> <td>0" (close nipple)</td> </tr> <tr> <td>10</td> <td>1" (nipple extension only)</td> </tr> <tr> <td>20</td> <td>2" (nipple extension only)</td> </tr> <tr> <td>30</td> <td>3" (minimum with union)</td> </tr> <tr> <td>40</td> <td>4"</td> </tr> <tr> <td>50</td> <td>5"</td> </tr> <tr> <td>60</td> <td>6"</td> </tr> <tr> <td>Other</td> <td>Specify length</td> </tr> </tbody> </table>	Code	Extension Length ("B" Dimension)	00	0" (close nipple)	10	1" (nipple extension only)	20	2" (nipple extension only)	30	3" (minimum with union)	40	4"	50	5"	60	6"	Other	Specify length
Code	Extension Length ("B" Dimension)																		
00	0" (close nipple)																		
10	1" (nipple extension only)																		
20	2" (nipple extension only)																		
30	3" (minimum with union)																		
40	4"																		
50	5"																		
60	6"																		
Other	Specify length																		
	<table border="1"> <thead> <tr> <th>Code</th> <th>Head Connections (Instrument x Conduit)</th> </tr> </thead> <tbody> <tr> <td>A</td> <td>1/2" NPT x 1/2" NPT</td> </tr> </tbody> </table>	Code	Head Connections (Instrument x Conduit)	A	1/2" NPT x 1/2" NPT														
Code	Head Connections (Instrument x Conduit)																		
A	1/2" NPT x 1/2" NPT																		
	<table border="1"> <thead> <tr> <th>Code</th> <th>Gasket Type</th> </tr> </thead> <tbody> <tr> <td>1</td> <td>Weatherproof - 200°F maximum - Industry Standard.</td> </tr> </tbody> </table>	Code	Gasket Type	1	Weatherproof - 200°F maximum - Industry Standard.														
Code	Gasket Type																		
1	Weatherproof - 200°F maximum - Industry Standard.																		

19	A	00	A	1
----	---	----	---	---

Sample Model Number
Your Model Number

United States of America

707 Jeffrey Way
Round Rock
Texas 78665-2408
USA

Tel: +1 512-434-2800

United Kingdom

Innovation House
Lancaster Road
Ferndown Industrial Estate
Wimborne
Dorset BH21 7SQ
UK

Tel: +44 (0) 1202 850 450

For more information

Web: cwic.curtisswright.com

Email: sales@nspi.curtisswright.com

About Curtiss-Wright

Curtiss-Wright Round Rock and Wimborne have worked with nuclear and industrial customers for over 60 years. We support customers across the world from facilities located in the US and UK. Our solutions are embedded in strategic national infrastructure and our people are active partners in customer programs that are focused on delivering advanced future nuclear and industrial capabilities.

Curtiss-Wright Corporation (NYSE: CW) is a global integrated business that provides highly engineered products, solutions and services mainly to Aerospace & Defense markets, as well as critical technologies in demanding commercial power, process and industrial markets. We leverage a workforce of approximately 8,600 highly skilled employees who develop, design and build what we believe are the best engineered solutions to the markets we serve. Building on the heritage of Glenn Curtiss and the Wright brothers, Curtiss-Wright has a long tradition of providing innovative solutions through trusted customer relationships.