

Model 305 spring loaded RTD

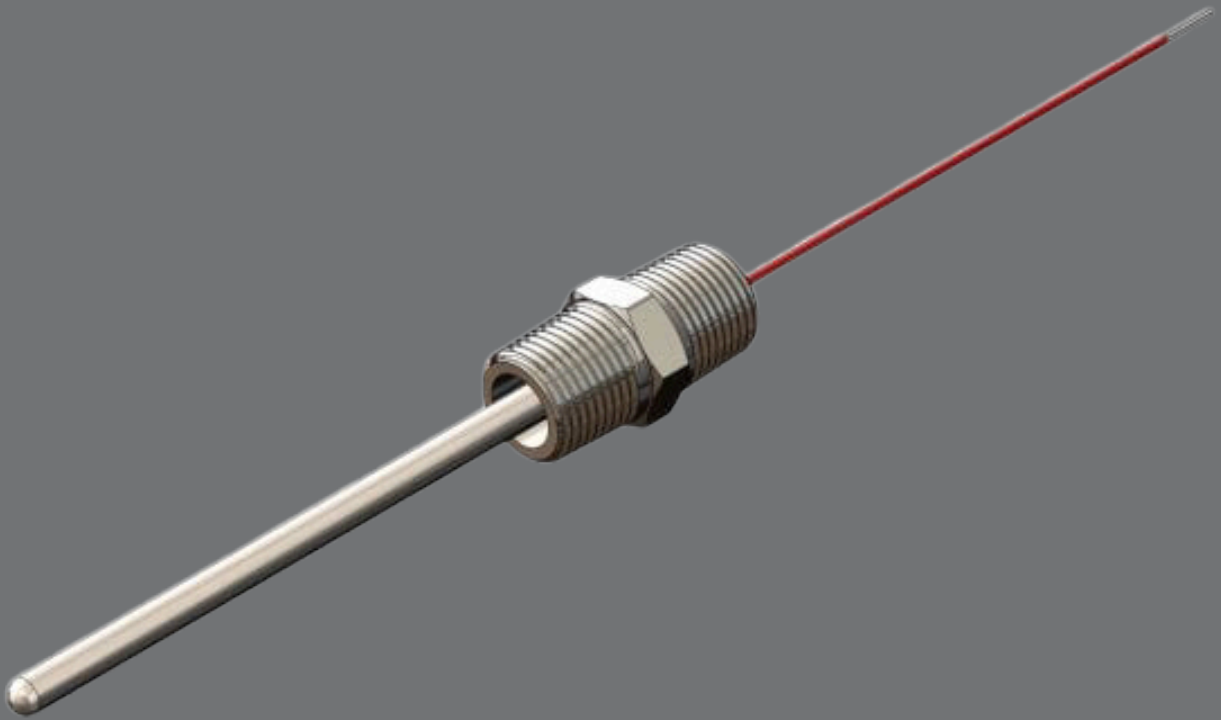

Overview

Designed for applications where a spring-loaded threaded male fitting is required for mounting. It is intended to be used with a thermowell and to be compatible with any head that will accept a 1/2" NPT instrument thread. The spring-loading action of this RTD ensures proper contact with the tip of the thermowell for maximum heat transfer.

Refer to Model 301, 302, 303, & 304 if threaded fitting is not required. Refer to Model 201 if welded fitting is required.

Technical specification

Feature	Description
Element type	Standard platinum, 100 ohms @ 0C (32F), .00385 TCR, with optional Pt Ro and TCRs available
Accuracy	Standard DIN-B, with optional DIN-A and others available upon request
Construction	Standard 500°F service temperature, with optional high temperature and rugged constructions available
Lead wire configuration	Standard 3 Wire, with optional 2, 4, 6 or 8 wire
Sensor sheath diameter	Standard 1/4" diameter, with optional 1/8", 3/16" and others available
Sheath length	Typically 1-1/2" to 42", with custom lengths available
Lead wire length	Standard 6", with custom length available
Connections	Options of standard and miniature sizes, as well as standard and high temperature ratings
Fittings	Optional compression and spring loaded fittings with various NPT connections
Insulation resistance	Greater than 100 Megohms @ 100VDC @ 21C (70F)

Technical specification

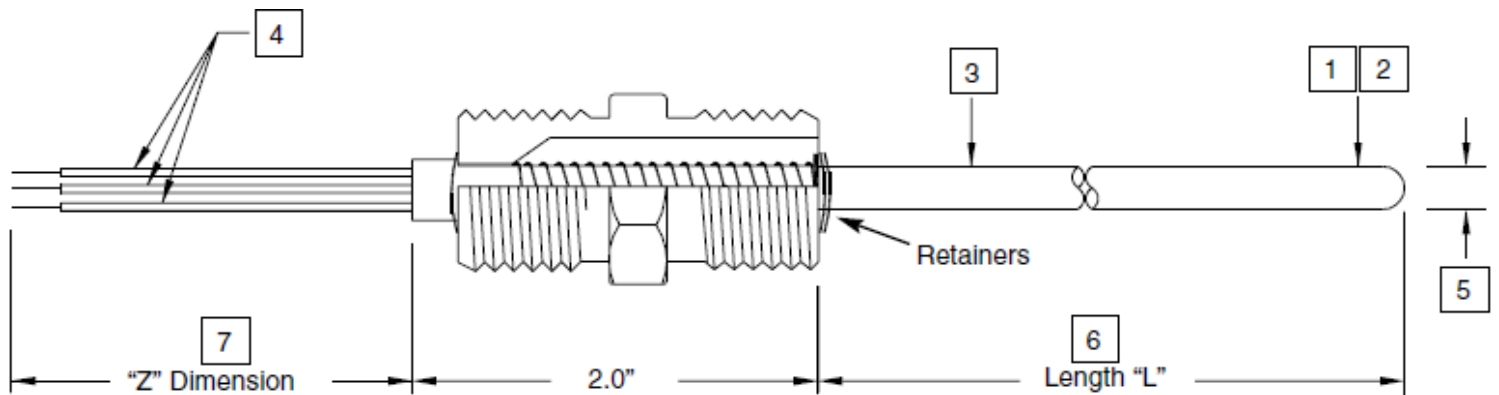

1. Base Model	Base Model/Series Number.
2. A. Accuracy:	<i>Standard</i> Class B (no code) <i>High</i> Class A (code H) <i>Special</i> Customer Specified (code S) * Industry Standard is DIN Curve (code 01B), Platinum, 100@ 0°C. Conforms to IEC 751.
B. TCR:	Temperature Coefficient of Resistance is the temperature vs. resistance characteristics of a given metal (Pt, Cu & Ni) used in manufacturing the RTD. Determines the curve of the RTD.
C. Ice Point Resistance:	R ₀ - Resistance at 0°C (32°F)
3. Construction:	Code A - 316SS tube and wire construction, thin film element, Teflon insulated lead wire. Code C - 316SS tube and wire construction, fiberglass insulated lead wire. Code B & D - MgO construction, Teflon insulated lead wire.
4. Lead Wires:	<div style="display: flex; justify-content: space-around; align-items: flex-start;"> <div style="text-align: center;"> <p>3 - Wire</p> </div> <div style="text-align: center;"> <p>4 - Wire</p> </div> <div style="text-align: center;"> </div> <div style="text-align: center;"> </div> </div>
5. Sheath Diameter:	.250" (1/4") is the industry standard.
6. Sheath Length:	Bottom of fitting to tip of sensor. See sizing chart in RTD General Specifications.
7. Lead Wire Length:	Length of wires beyond sheath.
8. Water resistant:	Increases moisture protection for humid environments.

Technical specification

Model	Description		
305	Spring-Loaded, 1/2" X 1/2" NPT Hex Nipple RTD (All Housings)		
1	Code	R ₀ & Temperature Coefficient	
	01B	100 ohm Platinum .00385055 TCR 100 ohms @ 0°C - Industry Standard	
	01A	100 ohm Platinum .003902 TCR 100 ohms @ 0°C	
	10A	1000 ohm Platinum .003902 TCR 1000 ohms @ 0°C	
	10B	1000 ohm Platinum .00385055 TCR 1000 ohms @ 0°C	
	12N	120 ohm Nickel .00672 TCR 120 ohms @ 0°C	
	09C	10 ohm Copper (9.035) .004274 TCR 10 ohms @ 25°C	
	Add Code "H" for higher accuracy Add Code "S" for special accuracy Add Code "M_", ME for matched to element, MT for matched to transmitter, MP for two matched probes.		
	2	Code	Construction Temperature Limit
		A	500° F Maximum
C		900° F Maximum (Platinum Only)	
D		1200° F Maximum (Platinum Only)	
3	Code	Number of Lead Wires	
	2	2-Wire (No lead Compensation)	
	3	3-Wire (Lead Compensation)	
	4	4-Wire (Complete Compensation)	
	6	Dual 3-Wire (With dual element)	
4	Code	Sheath Diameter	
	C	.250" (1/4") Diameter	
5	Code	Sheath Length	
	XXX.X	Specify length to nearest 0.1"	
6	Code	Lead Wire Length	
	Z006	6" - Standard with head	
	Z024	24" - Standard without head	
7	Code	Option	
	W	Water Resistant	
8			

305 - 01B - A - 3 - C - 012.0 - Z006 - Sample Model Number
 - - - - - - - - - Your Model Number

Technical specification

305	Spring Loaded Sensor with 1/2"NPT Hex Fitting															
	Code	Sensing Element	TCR (ohms/C/C)	Accuracy												
	01B	100 ohm Platinum	.00385055	DIN-B Standard												
	01BW	100 ohm Platinum - wire wound	.00385055	DIN-B												
	01AW	100 ohm Platinum - wire wound	.003902	DIN-B equivalent												
	10AW	1000 ohm Platinum - wire wound	.003902	DIN-B equivalent												
	10B	1000 ohm Platinum	.00385055	DIN-B												
	10BW	1000 ohm Platinum - wire wound	.00385055	DIN-B												
	12N	120 ohm Nickel	.00672	+/- .85deg.C(.60 ohms) at 0deg.C												
	09C	10 ohm Copper	.004275	+/- .25deg.C(.05 ohms) at 0deg.C												
	Option: Add 'H' for high accuracy - DIN-A (Platinum elements only)															
	Option: Add 'S' for 1/6 DIN accuracy (Platinum elements only)															
	Option: Add 'MT' for matched calibration to transmitter															
	Code	Temperature Range Limit / Construction	Sensing Tip	Lead End Max.												
	A	316SS Sheath, Teflon insulated internal & external leads	-58 to 500F	500F Standard												
	C	316SS Sheath, Fiberglass insulated internal & external leads (Platinum only)	-58 to 900F	900F												
	E	316SS Sheath, Fiberglass internal & Teflon external insulated leads (Platinum only)	-58 to 900F	500F												
	D	316SS MgO Sheath, Teflon insulated external leads (Platinum only)	-58 to 1200F	500F												
	B	Inconel MgO Sheath, Teflon insulated external leads (Platinum only)	-58 to 1700F	500F												
	L	316SS Sheath, Teflon insulated internal & external leads (Platinum only)	-328 to 500F	500F												
	Code	Lead Wire Configuration														
	2	2 wire (no lead compensation)														
	3	3-wire (lead compensation) Standard														
	4	4-wire (complete lead compensation)														
	6	dual 3-wire (2 sensing elements - .187" diameter sheath or larger)														
	8	dual 4-wire (2 sensing elements - .187" diameter sheath or larger)														
	Code	Sheath Diameter														
	C	.250" (1/4") Diameter - Standard														
	Other	Consult Factory														
	Code	Sheath Length (QuickShip limit: 1.5" to 44")														
	xxx.x	Specify length to the nearest 0.1 inch														
	Code	Lead Wire Configuration (inches) (QuickShip Limit: 24" max.)														
	Zxxx	Specify flying lead length Standard Z024 (Z006 if used w/head)														
	Jxxx	Specify jacketed lead length														
	Sxxx	Specify jacketed w/shield lead length														
	Code	Options														
	SF	Silicone Free														
305	-	01B	-	A	-	3	-	C	-	010.0	-	2006	-	-	-	-

United States of America

707 Jeffrey Way
Round Rock
Texas 78665-2408
USA

Tel: +1 512-434-2800

United Kingdom

Innovation House
Lancaster Road
Ferndown Industrial Estate
Wimborne
Dorset BH21 7SQ
UK

Tel: +44 (0) 1202 850 450

For more information

Web: cwic.curtisswright.com

Email: sales@nspi.curtisswright.com

About Curtiss-Wright

Curtiss-Wright Round Rock and Wimborne have worked with nuclear and industrial customers for over 60 years. We support customers across the world from facilities located in the US and UK. Our solutions are embedded in strategic national infrastructure and our people are active partners in customer programs that are focused on delivering advanced future nuclear and industrial capabilities.

Curtiss-Wright Corporation (NYSE: CW) is a global integrated business that provides highly engineered products, solutions and services mainly to Aerospace & Defense markets, as well as critical technologies in demanding commercial power, process and industrial markets. We leverage a workforce of approximately 8,600 highly skilled employees who develop, design and build what we believe are the best engineered solutions to the markets we serve. Building on the heritage of Glenn Curtiss and the Wright brothers, Curtiss-Wright has a long tradition of providing innovative solutions through trusted customer relationships.