

N-E11 and N-E13 series nuclear electronic pressure transmitters



N-E13DH



N-E13DM



N-E11GM

Overview

These transmitters measure absolute, gauge or differential pressure and transmit a proportional 4 to 20 or 10 to 50 mA dc signal. They are 2-wire transmitters that have been type-tested for applications under seismic, radiation, aging, and loss-of-cooling accident (LOCA) environments of Nuclear Power Plants per IEEE 323-1974 and 344-1975 requirements.

Qualified for nuclear applications

A Design Control and Quality Assurance Program has been established which complies with ANSI

N45.2 and Code of Federal Regulations 10CFR50, Appendix B. Certificates of Testing are provided with each transmitter relating to nuclear cleaning, hydrostatic testing, and calibration. Production transmitters have been type tested to demonstrate their performance, under typical accident conditions, for Class IE, in-containment applications of Nuclear Power Generating Stations. Type test reports (user documents) are available.

Serviceability

The complete line of N-E11 and N-E13 Series transmitters are supplied with detailed instructions and parts lists that provide the user considerable flexibility and capability for field repair.

Field interface

Optional junction box allows quick and easy field wiring to terminal blocks without the need for nuclear splices or seals. Optional seismic mounting brackets allow vertical or horizontal pipe mounting, or wall mounting.

Operating conditions

Influence	Reference operating conditions	Normal operating conditions limits (OBE)	Operative limits (DBE)
Ambient temperature (topworks with amplifier)	24 ± 2°C (75 ± 3°F)	0 and 80°C (32 and 180°F)	-18 and +216°C ^(a) (0 and 420°F)
Process temperature	24 ± 2°C (75 ± 3°F)	0 and 80°C (32 and 180°F)	-18 and +120°C ^(a) (0 and 250°F)
Relative Humidity	50 ± 10%	No limit	No limit
Ambient pressure	101 kPa (14.7 psi) (atmospheric)	94 and 108 kPa (13.7 and 15.7 psi)	586 kPa (85 psi)
Vibration and seismic ('g' load in any plane)	Negligible	Per OBE test profile (see Figure 1)	Per SSE test profile (see Figure 2)
Position	Upright	0° to 90° tilt in any plane	No limit
Radiation rate (Gamma)	Negligible	0.2 rad/h	3 X 10 rad/h ^(b)
Total integrated dose (TID) Gamma-air equivalent	Negligible	3.5 x 10 ⁴ rad	2.0 x 10 ⁸ rad ^(c)

(a) LOCA peak is 216°C (420°F) for a 3-minute duration, and 176°C (350°F) for a 10-minute duration. Refer to LOCA/HELB test profile Figure 6.

(b) Accident dose rate is 3 x 10⁶ rad/h for 2 hours, then 1 x 10⁶ rad/h.

(c) TID includes 1.5 x 10⁸ rad accident dosage plus 0.3 x 10⁸ rad gamma equivalent for a beta TID of 1.5 x 10⁹ rad. Margin also included in TID.

Operating conditions

Influence	Reference operating conditions	Normal operating conditions limits (OBE)	Operative limits (DBE)
Ambient temperature (topworks with amplifier)	24 ± 2°C (75 ± 3°F)	0 and 80°C (32 and 180°F)	-18 and +216°C ^(a) (0 and 420°F)
Process temperature	24 ± 2°C (75 ± 3°F)	0 and 80°C (32 and 180°F)	-18 and +120°C ^(a) (0 and 250°F)
Relative Humidity	50 ± 10%	No limit	No limit
Ambient pressure	101 kPa (14.7 psi) (atmospheric)	94 and 108 kPa (13.7 and 15.7 psi)	586 kPa (85 psi)
Vibration and seismic ('g' load in any plane)	Negligible	Per OBE test profile (see Figure 1)	Per SSE test profile (see Figure 2)
Position	Upright	0° to 90° tilt in any plane	No limit
Radiation rate (Gamma)	Negligible	0.2 rad/h	3 X 10 rad/h ^(b)
Total integrated dose (TID) Gamma-air equivalent	Negligible	3.5 x 10 ⁴ rad	2.0 x 10 ⁸ rad ^(c)

(a) LOCA peak is 216°C (420°F) for a 3-minute duration, and 176°C (350°F) for a 10-minute duration. Refer to LOCA/HELB test profile Figure 6.

(b) Accident dose rate is 3 x 10⁶ rad/h for 2 hours, then 1 x 10⁶ rad/h.

(c) TID includes 1.5 x 10⁸ rad accident dosage plus 0.3 x 10⁸ rad gamma equivalent for a beta TID of 1.5 x 10⁹ rad. Margin also included in TID.

Operating conditions

Figure 1. Required response spectrums (RRS) for operating basis earthquake (OBE), 1% damping

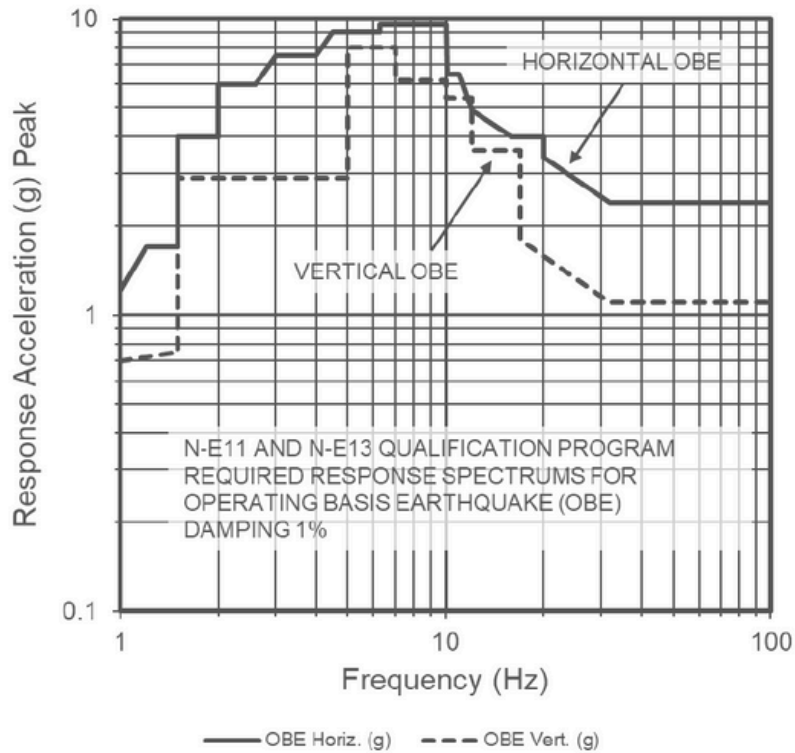
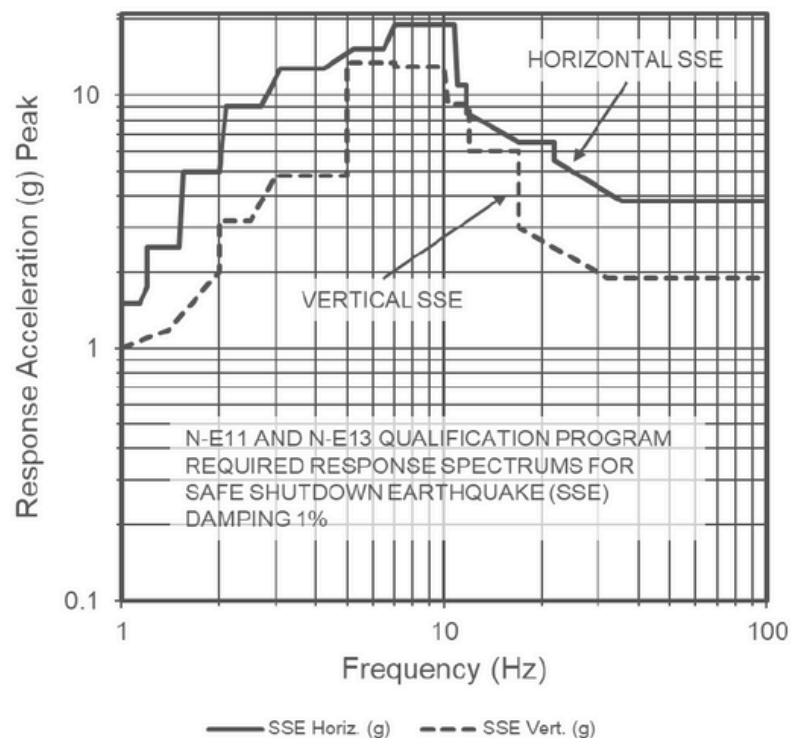

Figure 2. Required response spectrums (RRS) for safe shutdown earthquake (SSE), 1% damping



Functional specifications

N-E11AH series absolute pressure transmitters

Span, range and maximum overrange pressure

Transmitter series	Sensor code (capsule)	Span limits (psia)	Range limits ^(a, b) (psia)	Maximum overrange ^(c) pressure (psia)
N-E11AH	A	10 and 80	0 and 90	90
	B	20 and 200	0 and 350	350
	C	40 and 400	0 and 750	750

(a) Suppressed-zero ranges require optional zero suppression kit so that ranges within upper range limit can be obtained. Sum of lower range value and calibrated span must not exceed upper range limit. Also, for the N-E11AH only, the lower range value cannot exceed nine times the minimum span for each capsule

(b) Maximum operating pressure may not exceed the maximum range limits listed.

(c) Transmitters have been factory-tested at the maximum overrange pressure for one minute with no degradation of performance.

N-E11DM series differential pressure transmitters

Span, range and maximum differential pressure

Transmitter series	Sensor code (capsule)	Span limits (psid)	Range limits ^(a, b) (psid)	Maximum differential ^(c) pressure (psid)
N-E11DM	B	20 and 200	-180 and +350	350
	C	40 and 400	-360 and +750	750
	D	100 and 1000	-900 and +1500	1500
	E	200 and 2000	-1800 and +3000	2000

Functional specifications

(a) Nonzero based ranges require optional zero elevation-suppression kit. With this optional kit, zero may be elevated or suppressed to as much as nine times the minimum span for each capsule. Upper and lower range values must not exceed the range limits of the capsule.

(b) Negative values indicate that the higher of the two measured pressures is on the normal 'low side' (body side) of the transmitter. Positive values indicate a higher pressure on the 'high side'.

(c) Maximum operating pressure (static + differential) = 21 MPa (3000 psi). CAUTION: During startup and shutdown do not damage sensor by exceeding applicable maximum differential pressure.

N-E11GM series gauge pressure transmitters

Span, range and maximum overrange pressure

Transmitter series	Sensor code (capsule)	Span limits (psi)	Range limits ^(a, b) (psi)	Maximum overrange ^(c) pressure (psi)
N-E11GM	A	10 and 80	-15 and +100	100
	B	20 and 200	-15 and +350	500
	C	40 and 400	-15 and +750	1000
	D	100 and 1000	-15 and +1500	2000
	E	200 and 2000	-15 and +3000	4000

(a) Nonzero based ranges require optional zero elevation-suppression kit. With this optional kit, zero may be suppressed to a maximum of nine times the minimum span for the N-E11GM capsules. However, the sum of zero suppression plus calibrated span must not exceed the upper range limit. Zero may be elevated to the lower range limit (full vacuum) with the kit.

(b) Maximum operating pressure may not exceed the maximum range limits listed.

(c) Transmitters have been factory-tested at the maximum overrange pressure for one minute with no degradation of performance.

Functional specifications

N-E13DL, DM and DH series differential pressure transmitters

Span, range and maximum static pressure

Transmitter series	Sensor code (capsule)	Span limits (inH ₂ O)	Range limits ^(a) (inH ₂ O)	Maximum differential pressure (psia)
N-E13DL	L	5 and 25	-25 and +25	500
N-E13DM	M	20 and 205	-205 and +205	2000
	H	200 and 850	-850 and +850	2000
N-E13DH	M	20 and 205	-205 and +205	3000
	H	200 and 850	-850 and +850	3000

(a) Nonzero based ranges require optional zero elevation-suppression kit. Upper and lower range values must not exceed range limits.

Supply voltage and external loop resistance

The supply voltage limits are shown in Figures 3 and 4 (below) for both LOCA and non-LOCA applications.

Figure 3 is for Class IE Transmitters (Nuclear Classification Code CS-N/SRC) per IEEE 323-1974 and IEE 344-1975.

Figure 4 is for Class II Transmitters (Nuclear Classification Code CS-N/SRD), structural integrity only per IEEE 344-1975. However, for a given supply voltage, the limits of the transmitter external loop resistance are set.

To determine the actual loop resistance, add the series resistance of each component in the loop. Transmitter without a junction box is considered as 0 ohm. Transmitter with junction box has 10-ohm resistance for the 10 to 50 mA version, or 25 ohms for resistance for the 4 to 20 mA version.

Functional specifications

Figure 3. Supply voltage versus loop resistance for Class 1E transmitters

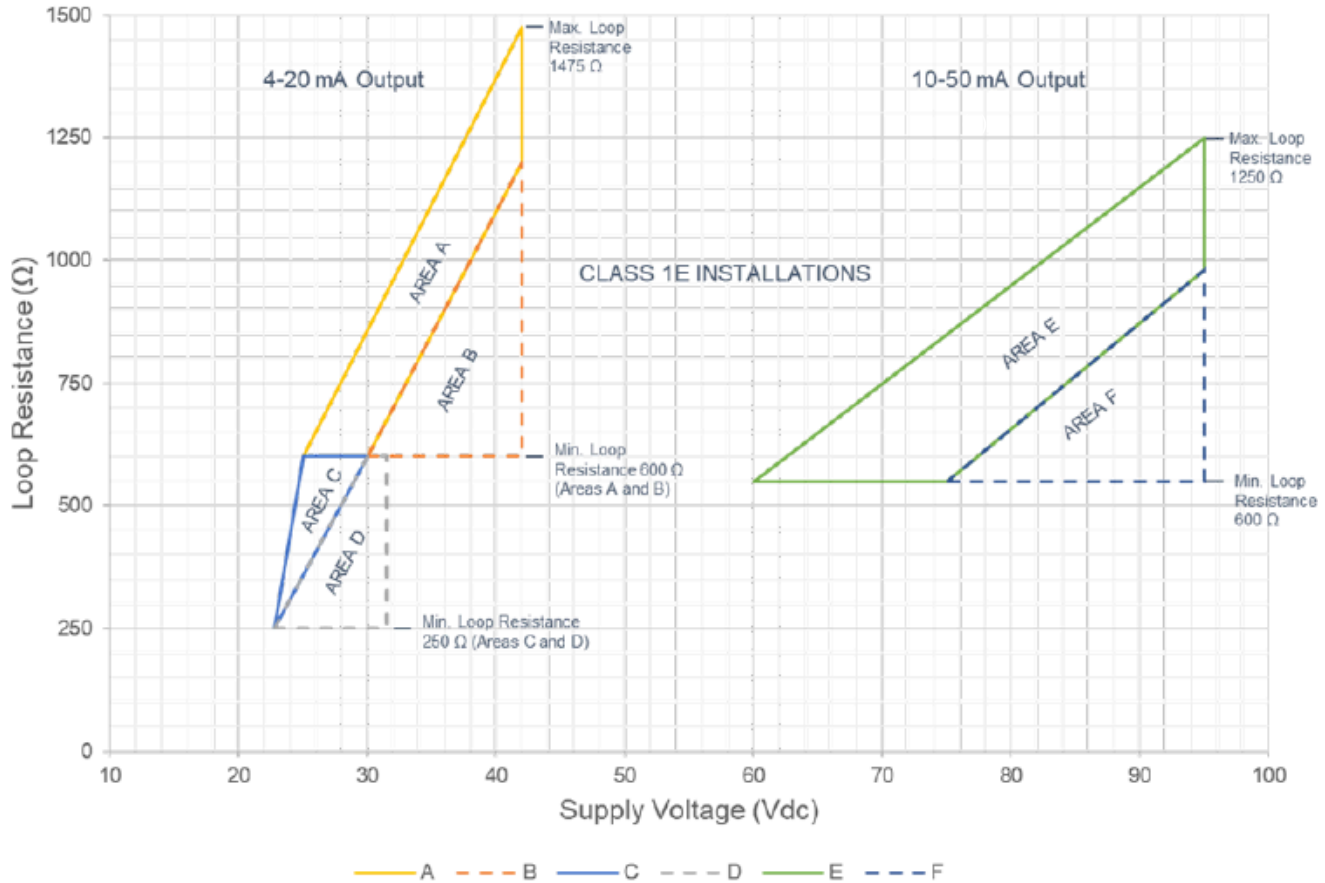

4-20 mA output

- Area A: Operating Area requirements for non-LOCA/HELB applications of transmitters up to 80°C (180°F) ambient. Transmitters powered by a separate power supply and not from a system module.
- Area B: Operating Area requirements for non-LOCA/HELB and LOCA/HELB applications of transmitters up to 216°C (420°F) ambient. Transmitters powered by a separate power supply and not from a system module.
- Area C: Operating Area requirements for non-LOCA/HELB applications of transmitters up to 80°C (180°F) ambient. Transmitters powered thru a system module using a field bus supply or other system source. Reference SPEC 200 System Input/Output Components N-2AI-12V and N-2AI-13V Converters. Loop resistances set by loop configuration internally in the I/O component.
- Area D: Operating Area requirements for non-LOCA/HELB and LOCA/HELB applications of transmitters up to 216°C (420°F) ambient. Transmitters powered thru a system module using a field bus supply or other system source. Reference SPEC 200 System Input/Output Components N-2AI-12V and N-2AI-13V Converters as in Area C.

10-50 mA output

- Area E — Operating Area for transmitters in non-LOCA/HELB applications up to 80°C (180°F) maximum.
- Area F — Operating Area for transmitters in LOCA/HELB applications up to 216°C (420°F) maximum and non-LOCA/HELB applications.

Functional specifications

Figure 4. Supply voltage versus loop resistance for Class II transmitters

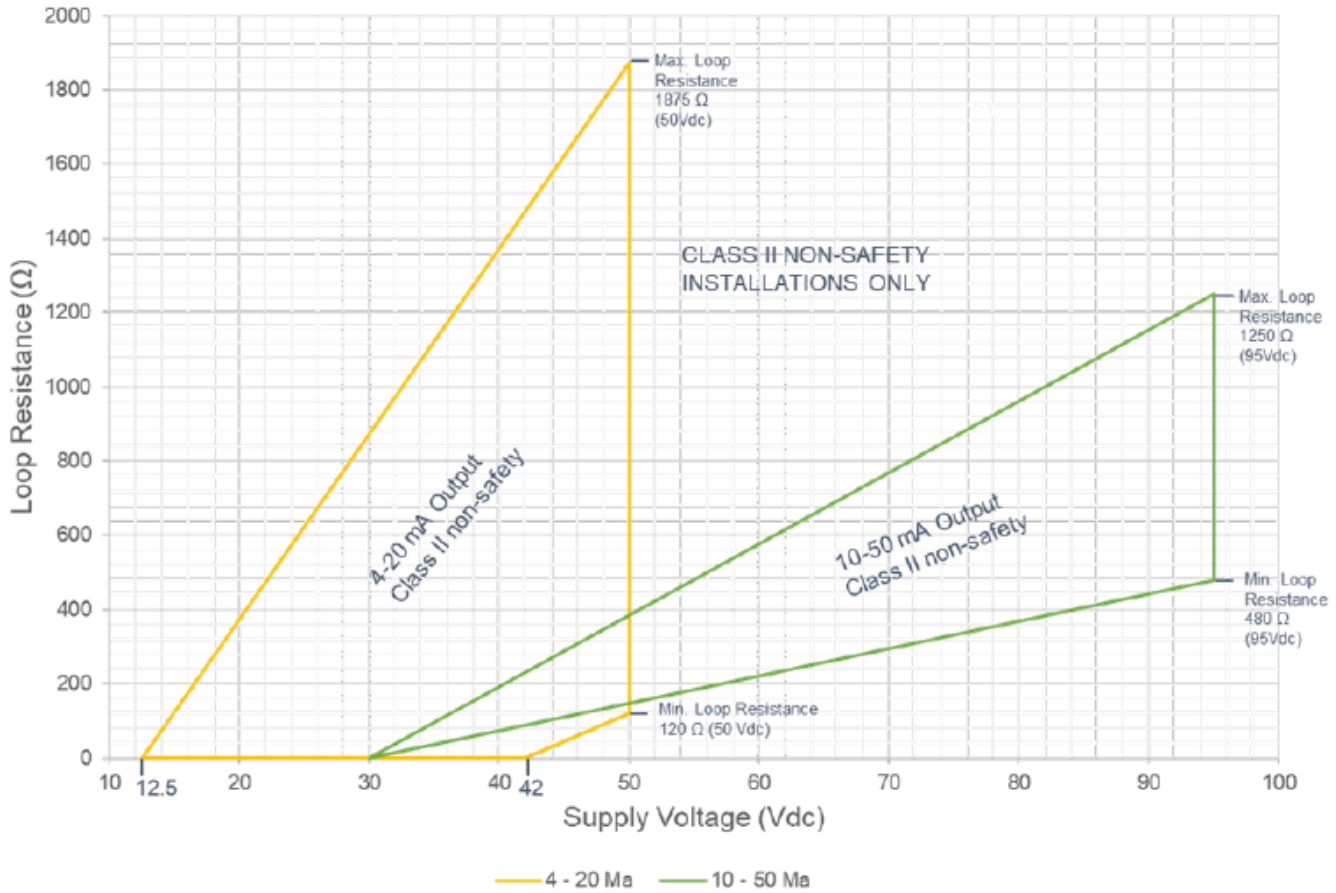

Performance specifications

Performance^(a) at reference operation conditions in percentage of calibrated span

Transmitter series	Sensor code (capsule)	Span between (inH ₂ O or PSI)	Accuracy	Repeatability	Hysteresis	Dead band	Reproducibility	Drift/year
N-E11AH	A	10 and 80 psia	±0.5	0.1	0.15	0.05	0.2	0.33
	B	20 and 200 psia			0.1		0.15	0.25
	C	40 and 400 psia			0.1		0.15	0.25
N-E11DM	B	20 and 200 psi ΔP			0.1		0.15	0.25
	C	40 and 400 psi ΔP			0.1		0.15	0.25
	D	100 and 1000 psi ΔP			0.1		0.15	0.25
	E	200 and 2000 psi ΔP			0.2		0.25	0.40
N-E11GM	A	10 and 80 psi			0.1		0.15	0.25
	B	20 and 200 psi			0.1		0.15	0.25
	C	40 and 400 psi			0.1		0.15	0.25
	D	100 and 1000 psi			0.1		0.15	0.25
	E	200 and 2000 psi			0.2		0.25	0.40

Performance specifications

Performance^(a) at reference operation conditions in percentage of calibrated span

Transmitter series	Sensor code (capsule)	Span between (inH ₂ O or PSI)	Accuracy	Repeatability	Hysteresis ^(b)	Dead band	Reproducibility ^(c)	Drift/year
N-E13DL	L		±0.5	0.15	See note (b)	0.05	0.2	0.33
N-E13DM	M			0.1	See note (b)		0.15	0.25
	H			0.1	0.1		0.15	0.25
	H			0.1	0.1		0.15	0.25
	H			0.1	0.1		0.15	0.25
N-E13DH	M			0.1	See note (b)		0.15	0.25
	H			0.1	0.1		0.15	0.25
	H	200 and 2000 psi ΔP		0.1	0.1		0.25	0.40

(a) Performance specifications listed are not applicable after a seismic, radiation, aging, or LOCA/HELB event.

(b) Hysteresis is 0.10% of span (0.05 inH₂O), whichever is larger.

(c) Reproducibility includes effects of hysteresis, repeatability, dead band, and drift over a one-hour period.

Performance specifications

DBE performance specifications

Variables		Maximum output shift, percentage of calibrated span at USL (see note a.)	
Normal radiation: TID 3.5×10^4 rad (gamma) $\pm 0.5 \pm 0.5$		± 0.5	± 0.5
Accident radiation: TID 2.0×10^4 rad (gamma); (Includes 0.3×10^4 rad gamma equivalent for beta TID of 1.5×10^4 rad plus 0.2×10^4 rad for margin)		± 2.5	± 6
Seismic (Refer to Figures 1 and 2, OBE and SSE response spectrums)	During OBEs and SSEs	± 5	± 5
	After OBEs and SSEs	± 1	± 1
LOCA/HELB (see Figure 5 and note b.)	First three hours of test profile	± 3	± 8
	From 3 hours to 24 hours of test profile	± 2	± 6
	From 24 hours to 30 days (30 days at 176°F = 1 year at 120°F)	± 1	± 3

Note: The DBE performance specifications were derived from type testing transmitters at approximately 25% of upper span limit (USL) or greater. The table below lists the minimum acceptable span for the errors listed above at the extremes of the DBE conditions.

Output shifts at approx. 25% of USL may be used for all applications between the spans shown above and less than the USL. A more accurate analysis, based upon specific applications (or for spans less than shown above), can be provided by the factory.

B. Output shift for gauge pressure transmitters does not include ambient pressure effects.

Model	Sensor code	Min. acceptable span for extremes of DBE conditions
N-E11AH	A	20 psia
	B	50 psia
	C	100 psia
N-E11GM	A	20 psi
	B	50 psi
	C	100 psi
	D	250 psi
	E	500 psi
N-E11DM	B	50 psi
	C	100 psi
	D	250 psi
	E	500 psi
N-E13DL	L	10 inH ₂ O
N-E13DM/DH	M	50 inH ₂ O

Performance specifications

Figure 5. Qualified life versus service temperature

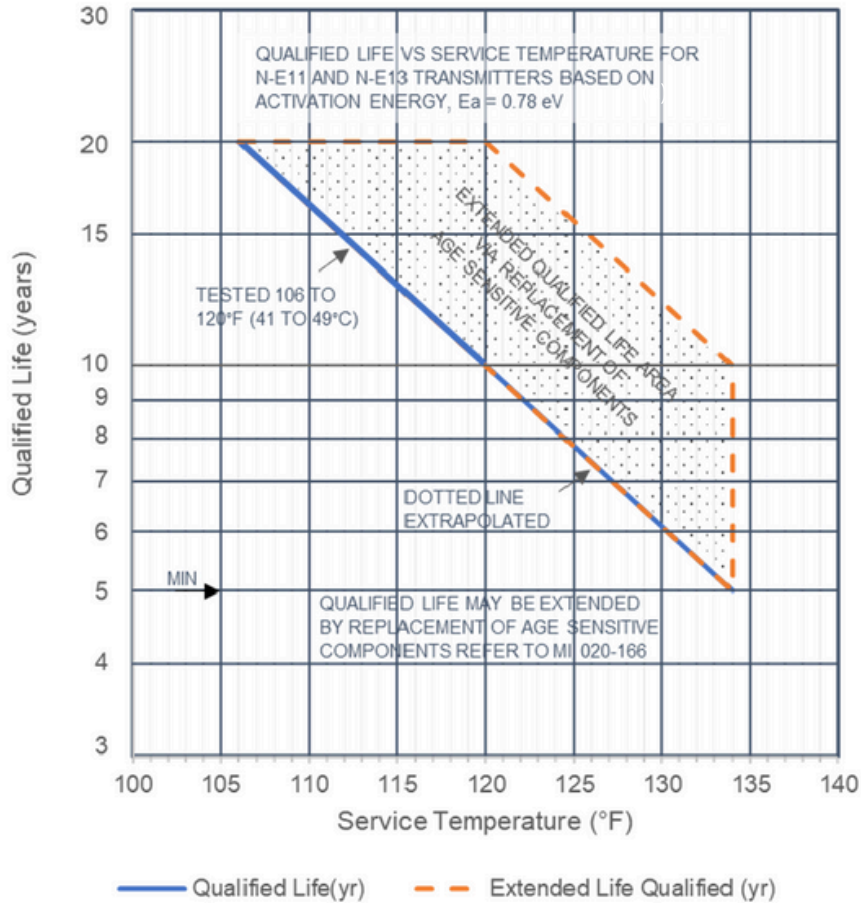
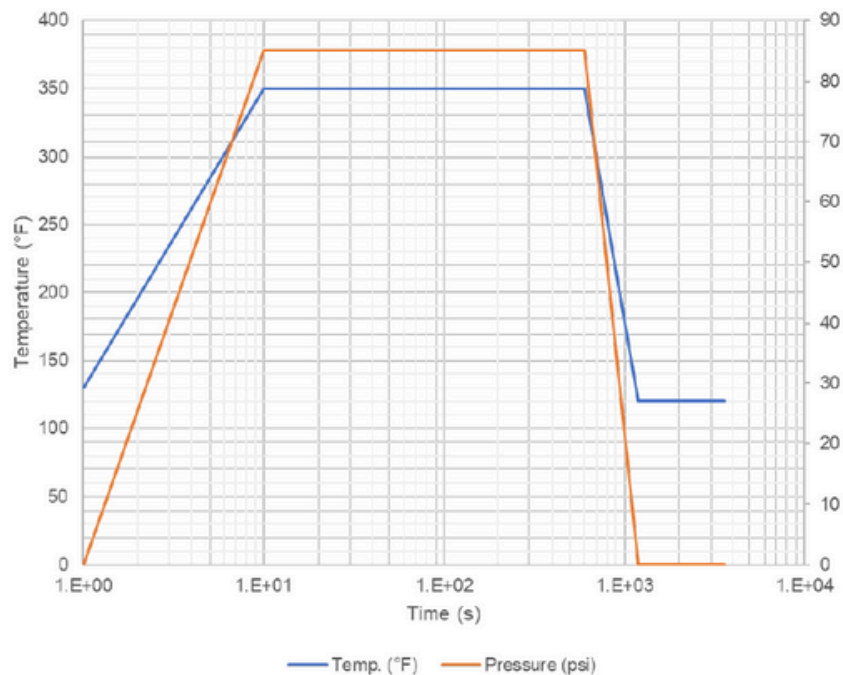
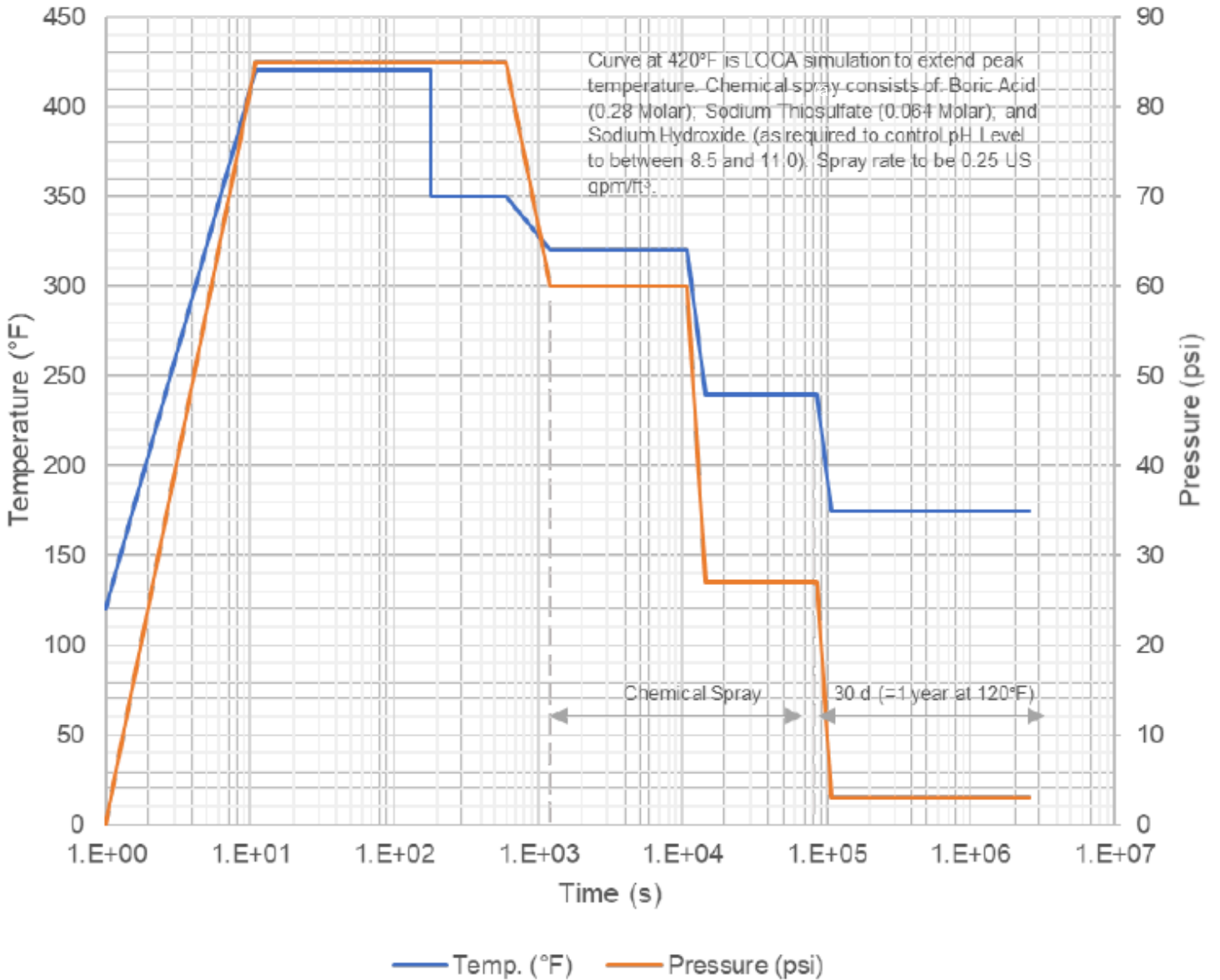

Figure 6. LOCA/HELB test profile, first transient to assure performance margin



Performance specifications

Figure 7. LOCA/HELB profile, local DBE event



Physical specifications

Enclosure Classification Meets IEC IP65 and provides the environmental protection of NEMA Type 4.

Topworks cover and base material

Code I: Cast iron per ASTM A48-64, Class 30, with Amercoat® 66 finish.

Code A: Low copper aluminum alloy with vinyl paint finish.

Application: The aluminum cover and base meet the same requirements as the nuclear transmitter with cast iron cover and base for seismic, radiation, aging, and LOCA/HELB, except where chemical sprays are present.

Instrument mounting: Mounting is on a vertical or horizontal DN 50 or 2 in pipe, or on a surface. A set of parts is optionally available for this purpose. Refer to Optional Features section for mounting selection.

Transmitter	Cast iron topworks ^(a, c)	Aluminum topworks ^(b, c)
N-E11AH	16kg/35lbs	8kg/18lbs
N-E11DM	16kg/35lbs	8kg/18lbs
N-E11GH	18kg/39lbs	10kg/22lbs
N-E13DL	23kg/50lbs	16kg/35lbs
N-E13DM	19kg/42lbs	11kg/25lbs
N-E13DH	25kg/55lbs	18kg/39lbs

Approximate mass: Refer to table to the right.

a) When optional cast iron, non-indicating junction box is used, add 2.3 kg/5lbs to total mass.

(b) When optional aluminum, non-indicating junction box is used, add 0.8 kg/1.8lbs to total mass.

(c) Also add 3.0 kg/6.7lbs when optional seismic mounting bracket is used with N-E11AH, N-E11DM; add 1.4 kg/3lbs with N-E11GH; and add 3.4 kg/7.5lbs with N-E13DL, N-E13DM, and N-E13DH.

Bottomworks materials

Transmitter bottomworks non-process-wetted and process-wetted-materials

Transmitter	Body bolts	Body	Process connector	Sensor	Lower force bar	Fore bar diapragm	Process connector gasket	Sensor gasket	Force bar gasket
N-E11AH	Zinc plated AISI 4142 high strength steel per ASTM A193-B7 ^(a)	316 ss	316 ss	316 ss	316 ss	Cu-Ni alloy	316 ss	Silicone elastomer	Silicone elastomer
N-E11DM		316 ss		316 ss	316 ss		-	Silicone elastomer	Silicone elastomer
N-E11DL		Cast iron ^(a)		Ni-Span C	316 ss ^(a)		-	-	Silicone elastomer ^(a)
N-E13DL		316 ss		316 ss	316 ss		316 ss	316 ss	Silicone elastomer
N-E13DM		316 ss		316 ss	316 ss		316 ss	316 ss	Silicone elastomer
N-E13DH		316 ss		316 ss	316 ss		316 ss	316 ss	Silicone elastomer

(a) These materials are non-process wetted. All other listed materials are process wetted.

Procedures, tests and certificates

Qualification program

- Class IE Per IEEE 323-1974 and IEEE 344-1975
- Class II Per IEEE 344-1975 (Structural integrity only)
- Standard tests and certificates
- Nuclear Cleaning To 1 ppm chloride content.
- Hydrostatic Test At 150% of rated pressure.
- Calibration Certificate is provided.
- Certificate of Compliance
- Class IE (Safety related: tested per IEEE 323-1974, IEEE 344-1975; Qualified to IEEE 323-1974/1983 and IEEE 344-1975/1987 by Equipment Qualification Similarity Certificate).
- Class II (Structural integrity: to IEEE 344-1975/1987).

Standard procedures

- Design Control In accordance with ANSI N45.2 and Code of Federal Regulation 10CFR50, Appendix B.
- Quality Assurance Program In accordance with: 10CRF21; 10CFR50, Appendix B; ANSI/ASME N45.2, Quality Assurance Program Requirements for Nuclear Plants; ANSI/ASME NQA-1-2015; CSA-N299.1 (formerly Z299.1), Canadian Quality Assurance Program – Category 1; RCC-E A-5000, Quality Assurance; IAEA50-C-QA (Rev. 1), Code on the Safety of Nuclear Power Plants: Quality Assurance.

Design qualification

These transmitters have been designed to meet the requirements of applicable Product Qualification Standards. The applicable standards provide the methodology for proving device performance under generic environments as established in the Foxboro® Transmitter Qualification Program (QOAC10). This includes Design Basis Event (DBE) environments. User documents, supporting the qualification tests, are available as required.

Nuclear qualifications documents

The Foxboro® N-E10 Series (N-E11 and N-E13) are qualified to IEEE 323-1974 and 344-1975 per:

- Foxboro® Nuclear Qualification Test Report Plan/Procedure Q0MC10 Rev. A.
- Test Report QOAC11 Rev. A, Foxboro® Corporate QA Laboratory Test Report 83-6076 Rev. A (includes Wyle Laboratories Report 45592-4) dated 05/18/1983.
- Curtiss-Wright document 0010-001-0024-PRC Rev. 0 Addendum to N-E10 Qualification Report QOAC11 Rev. A Effects on Qualified Life from Internal Self-Heating of Electronic Components dated 09/26/2019.
- Foxboro® Similarity Analysis QOAC12 Rev. D dated January 1992.
- Qualified to IEEE 323-1974/1983 and IEEE 344-1975/1987 by Equipment Qualification Similarity Certificate.

Type test reports (user documents), supporting qualification of these transmitters to IEEE Standards 323-1974 and 344-1975 (aging, seismic, LOCA, and radiation), are available on an as-needed basis. They are not routinely provided with every transmitter.

Procedures, tests and certificates

Qualification program

- Class IE Per IEEE 323-1974 and IEEE 344-1975
- Class II Per IEEE 344-1975 (Structural integrity only)
- Standard tests and certificates
- Nuclear Cleaning To 1 ppm chloride content.
- Hydrostatic Test At 150% of rated pressure.
- Calibration Certificate is provided.
- Certificate of Compliance
- Class IE (Safety related: tested per IEEE 323-1974, IEEE 344-1975; Qualified to IEEE 323-1974/1983 and IEEE 344-1975/1987 by Equipment Qualification Similarity Certificate).
- Class II (Structural integrity: to IEEE 344-1975/1987).

Standard procedures

- Design Control In accordance with ANSI N45.2 and Code of Federal Regulation 10CFR50, Appendix B.
- Quality Assurance Program In accordance with: 10CFR21; 10CFR50, Appendix B; ANSI/ASME N45.2, Quality Assurance Program Requirements for Nuclear Plants; ANSI/ASME NQA-1-2015; CSA-N299.1 (formerly Z299.1), Canadian Quality Assurance Program – Category 1; RCC-E A-5000, Quality Assurance; IAEA50-C-QA (Rev. 1), Code on the Safety of Nuclear Power Plants: Quality Assurance.

Design qualification

These transmitters have been designed to meet the requirements of applicable Product Qualification Standards. The applicable standards provide the methodology for proving device performance under generic environments as established in the Foxboro® Transmitter Qualification Program (QOAC10). This includes Design Basis Event (DBE) environments. User documents, supporting the qualification tests, are available as required.

Nuclear qualifications documents

The Foxboro® N-E10 Series (N-E11 and N-E13) are qualified to IEEE 323-1974 and 344-1975 per:

- Foxboro® Nuclear Qualification Test Report Plan/Procedure Q0MC10 Rev. A.
- Test Report QOAC11 Rev. A, Foxboro® Corporate QA Laboratory Test Report 83-6076 Rev. A (includes Wyle Laboratories Report 45592-4) dated 05/18/1983.
- Curtiss-Wright document 0010-001-0024-PRC Rev. 0 Addendum to N-E10 Qualification Report QOAC11 Rev. A Effects on Qualified Life from Internal Self-Heating of Electronic Components dated 09/26/2019.
- Foxboro® Similarity Analysis QOAC12 Rev. D dated January 1992.
- Qualified to IEEE 323-1974/1983 and IEEE 344-1975/1987 by Equipment Qualification Similarity Certificate.

Type test reports (user documents), supporting qualification of these transmitters to IEEE Standards 323-1974 and 344-1975 (aging, seismic, LOCA, and radiation), are available on an as-needed basis. They are not routinely provided with every transmitter.

Model codes

N-E11AH

- Nuclear Electronic Absolute Pressure Transmitter—High Range
- Output Signal: -H = 10 to 50 mA, 60 to 95 V dc; -I = 4 to 20 mA, 25 to 42 V dc
- Base and Cover Material: I = Cast Iron (For caustic spray environment); A = Aluminum
- Sensor Code—Span Limits: A = 70 and 560 kPa abs (10 and 80 psia); B = 140 and 1400 kPa abs (20 and 200 psia); C = 280 and 2800 kPa abs (40 and 400 psia)
- Process Connections: 2 = Tapped for 1/2 NPT; 4 = Tapped for R ½

N-E11DM

- Nuclear Electronic Differential Pressure Transmitter—Medium Range
- Output Signal: -H = 10 to 50 mA, 60 to 95 V dc; -I = 4 to 20 mA, 25 to 42 V dc
- Base and Cover Material: I = Cast Iron (For caustic spray environment); A = Aluminum
- Sensor Code—Span Limits: B = 0.14 and 1.4 MPa ΔP (20 and 200 psi ΔP); C = 0.28 and 2.8 MPa ΔP (40 and 400 psi ΔP); D = 0.70 and 7.0 MPa ΔP (100 and 1000 psi ΔP); E = 1.40 and 14.0 MPa ΔP (200 and 2000 psi ΔP)
- Process Connection: 1 = Tapped for 1/4 NPT; 2 = Tapped for 1/2 NPT; 3 = Tapped for R 1/4; 4 = Tapped for R ½

N-E11GM

- Nuclear Electronic Gauge Pressure Transmitter —Medium Range
- Output Signal: -H = 10 to 50 mA, 60 to 95 V dc; -I = 4 to 20 mA, 25 to 42 V dc
- Base and Cover Material: I = Cast Iron (For caustic spray environment); A = Aluminum
- Sensor Code—Span Limits: A = 0.07 and 0.56 MPa (10 and 80 psi); B = 0.14 and 1.4 MPa (20 and 200 psi); C = 0.28 and 2.8 MPa (40 and 400 psi); D = 0.7 and 7.0 MPa (100 and 1000 psi); E = 1.4 and 14.0 MPa (200 and 2000 psi)
- Process Connections: 1 – Tapped for 1/4 NPT; 2 = Tapped for 1/2 NPT; 3 = Tapped for R 1/4; 4 = Tapped for R 1/2; 5 = Machined to accept 9/16-18 AMINCO fitting (Do not use with Sensor Code A)

N-E13DL

- Nuclear Electronic Differential Pressure Transmitter—Low Range
- Output Signal: -H = 10 to 50 mA, 60 to 95 V dc; -I = 4 to 20 mA, 25 to 42 V dc
- Base and Cover Material: I = Cast Iron (For caustic spray environment); A = Aluminum
- Sensor Code—Span Limits: L = 1.3 and 6 kPa ΔP (5 and 25 inH2O ΔP)
- Process Connections: 0 = None (Body tapped for 1/4 NPT); 1 = 1/4 NPT; 2 = 1/2 NPT; 3 = R 1/4; 4 = R 1/2

N-E13DM

- Nuclear Electronic Differential Pressure Transmitter—Medium Range
- Output Signal: -H = 10 to 50 mA, 60 to 95 V dc; -I = 4 to 20 mA, 25 to 42 V dc
- Base and Cover Material: I = Cast Iron (For caustic spray environment); A = Aluminum
- Sensor Code—Span Limits: M = 5 and 51 kPa ΔP (20 and 205 inH2O ΔP); H = 5 and 210 kPa ΔP (200 and 850 inH2O ΔP)
- Process Connections: 0 = None (Body tapped for 1/4 NPT); 1 = 1/4 NPT; 2 = 1/2 NPT; 3 = R 1/4; 4 = R ½

Accessory

Note that a calibration accessory (0342-008-0060 TEST COVER, CAST IRON, N-E10 P/N B0137AZ) is offered for transmitters having a cast iron base and cover (Material code “I”).

Model codes

N-E13DH

- Nuclear Electronic Differential Pressure Transmitter—High Range
- Output Signal: -H = 10 to 50 mA, 60 to 95 V dc; -I = 4 to 20 mA, 25 to 42 V dc
- Base and Cover Material: I = Cast Iron (For caustic spray environment); A = Aluminum
- Sensor Code—Span Limits: M = 5 and 51 kPa ΔP (20 and 205 inH2O ΔP); H = 5 and 210 kPa ΔP (200 and 850 inH2O ΔP)
- Process Connections: 0 = None (Body tapped for 1/4 NPT); 1 = 1/4 NPT; 2 = 1/2 NPT; 3 = R 1/4; 4 = R 1/2; 5 = Machined to accept 9/16-18 AMINCO fitting

Optional model code selections

Optional feature	Description	Model code suffix ^(a)
Mounting bracket	Seismic mounting kit, for horizontal pipe mounting.	A
	Seismic mounting kit, for vertical pipe mounting.	B
	Seismic mounting kit, for wall (surface) mounting.	C ^(e)
Integral mounted non-indicating junction box	Cast iron, with 1 ohm resistor for 10 to 50 mA output.	D ^(c)
	Cast iron, with 10 ohm resistor for 10 to 50 mA output.	E ^(c)
	Cast iron, with 25 ohm resistor for 4 to 20 mA output.	F ^(c)
	Aluminum, with 1 ohm resistor for 10 to 50 mA output.	G ^(d)
	Aluminum, with 10 ohm resistor for 10 to 50 mA output.	H ^(d)
	Aluminum, with 25 ohm resistor for 4 to 20 mA output.	I ^(d)
Reverse output	20 to 4 mA output signal	J ^(f)
	50 to 10 mA output signal	K ^(f)
Range kit elevated or suppressed zero	Allows for suppressed-zero or elevated-zero ranges. The elevated zero kit is not applicable to the N-E11AH Series transmitters, since they are absolute pressure instruments and can have suppressed-zero ranges only.	L

(a) The optional feature suffix codes are added to the instrument Model Code as follows: N-E13DM-HIM1-AEK (Note that in the example given, three options were selected, -A, -E and -K.)

(c) Not available with aluminum cover and base (Material code "A").

(d) Not available with cast iron cover and base (Material code "I").

(e) Documentation and mounting hardware are identical to that provided for seismic mounting kit for the DN 50 or 2 in vertical pipe mounting.

(f) Includes Model Code Suffix -L, Range Kit Option.

Dimensions

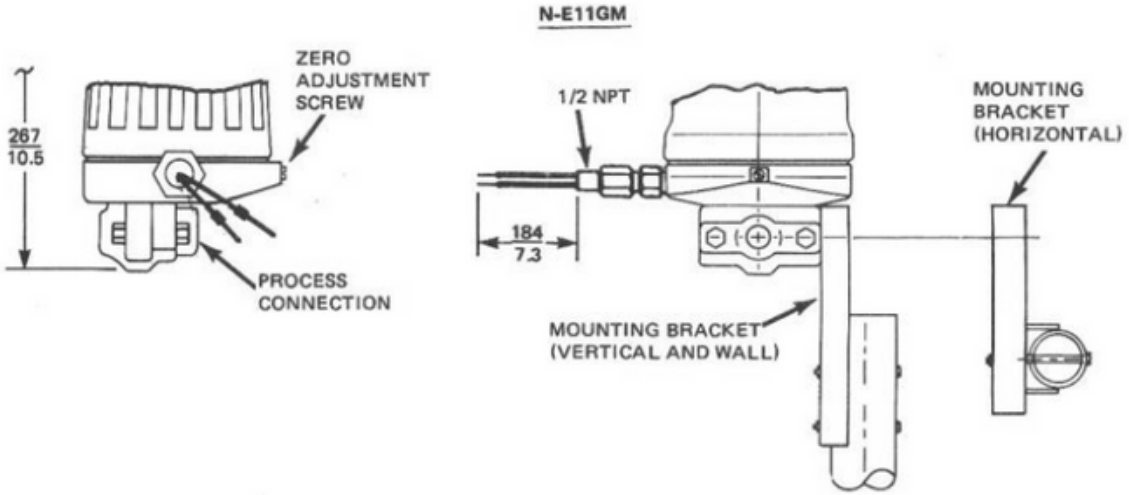
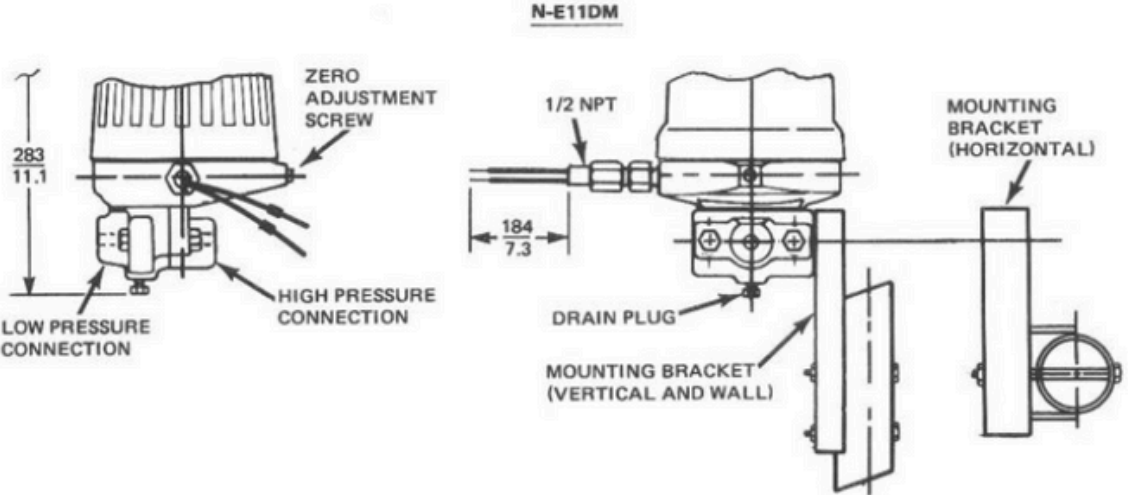
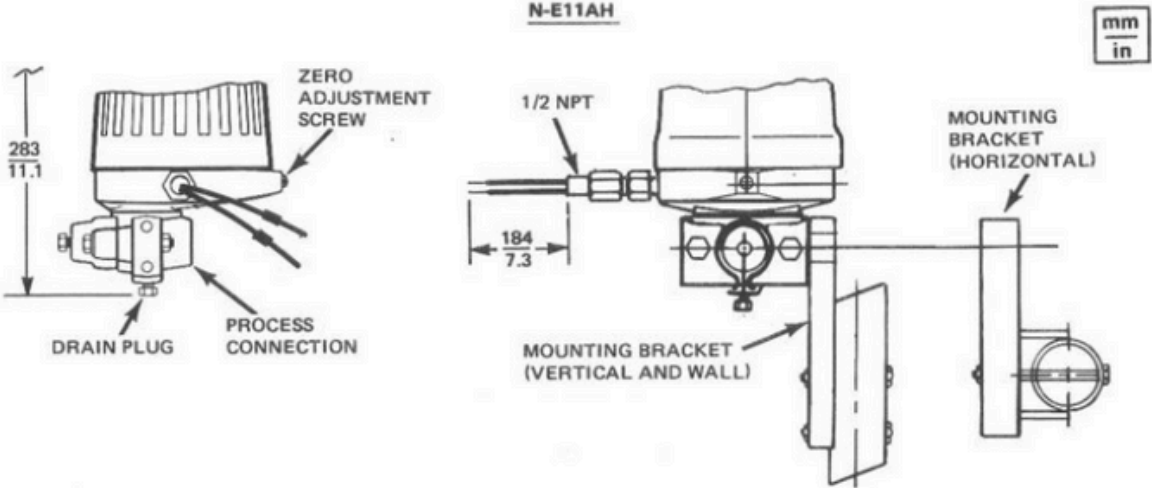

Dimensions

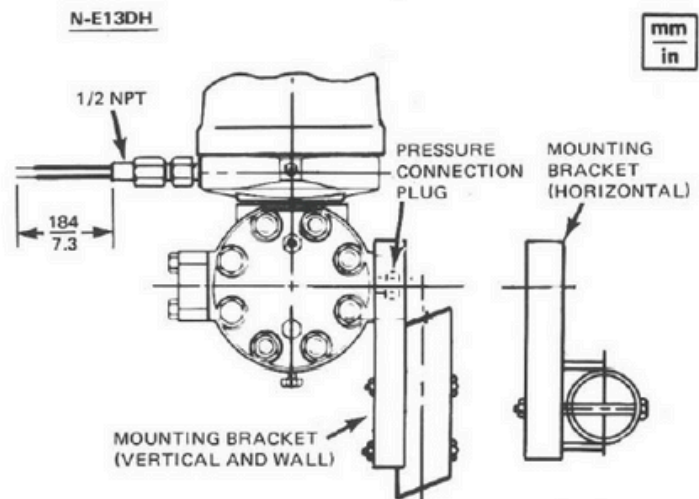
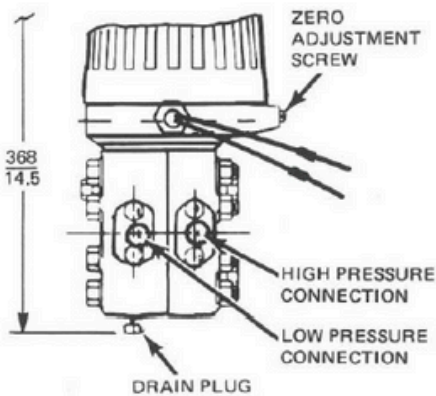
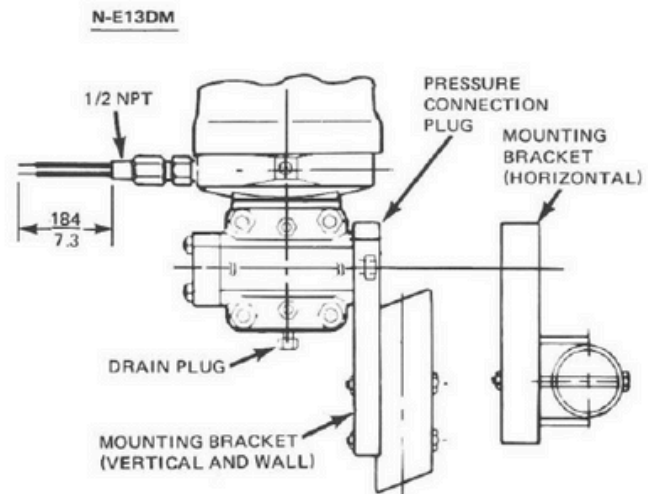
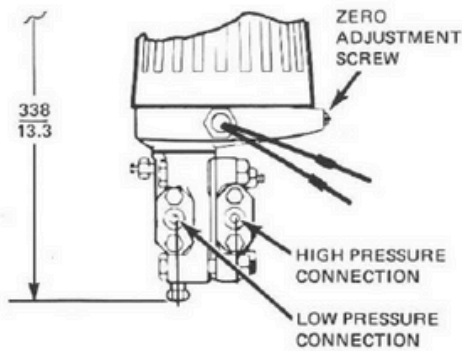
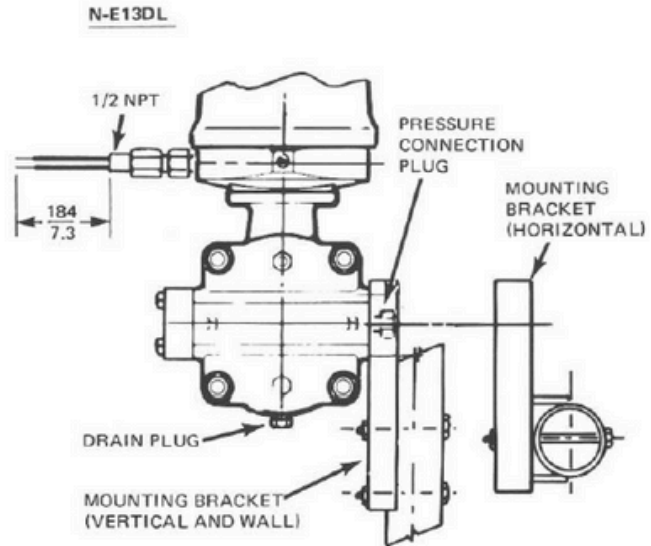
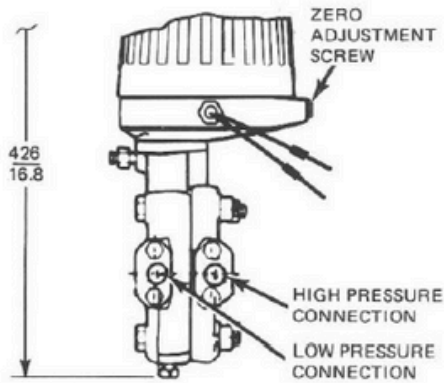

United States of America

707 Jeffrey Way
Round Rock
Texas 78665-2408
USA

Tel: +1 512-434-2800

United Kingdom

Innovation House
Lancaster Road
Ferndown Industrial Estate
Wimborne
Dorset BH21 7SQ
UK

Tel: +44 (0) 1202 850 450

For more information

Web: cwic.curtisswright.com

Email: sales@nspi.curtisswright.com

About Curtiss-Wright

Curtiss-Wright Round Rock and Wimborne have worked with nuclear and industrial customers for over 60 years. We support customers across the world from facilities located in the US and UK. Our solutions are embedded in strategic national infrastructure and our people are active partners in customer programs that are focused on delivering advanced future nuclear and industrial capabilities.

Curtiss-Wright Corporation (NYSE: CW) is a global integrated business that provides highly engineered products, solutions and services mainly to Aerospace & Defense markets, as well as critical technologies in demanding commercial power, process and industrial markets. We leverage a workforce of approximately 8,600 highly skilled employees who develop, design and build what we believe are the best engineered solutions to the markets we serve. Building on the heritage of Glenn Curtiss and the Wright brothers, Curtiss-Wright has a long tradition of providing innovative solutions through trusted customer relationships.